

卡式刀座 45°
CARTRIDGES (45°)

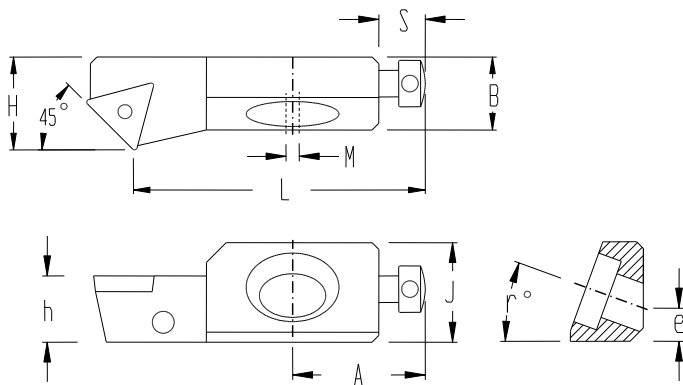

規格 SPECIFICATION	H	h	L	A	J	B	r°	e	M	S	最小加工徑 Min.Bore φD
SEP6- 45R	8	6	22	12	6	5	15°	2.5	1.0	4.5	18
SCP6- 45R	8	6	22	12	6	5	15°	2.5	1.0	4.5	18
STB6-45R	7	6	19.5	12	6	5	15°	2.5	1.0	4.5	18
STC8-45R	10	8	27	17	8	7	15°	3.2	2.0	7	28
STP8-45R/L	10	8	27	17	8	7	15°	3.2	2.0	7	28
STSCR-10CA-11	14	10	44	20	15	11	20°	5	2.0	7	38
STSCR-12CA-16	20	12	47	20	20	15	20°	6	2.0	8	50

部品 PARTS

規格 SPECIFICATION	適用刀片 INSERTS	刀片螺絲 INSERT SCREW	徑向調整螺絲 RADIAL ADJUSTING SCREW	軸向調整螺絲 AXIAL ADJUSTING SCREW	鎖固螺絲 LOCKING SCREW	刀片扳手 INSERT SCREW WRENCH
SEP6-45R	 					T 6
SCP6-45R	 					T 7
STB6-45R	 					T 6
STC8-45R	 					T 7
STP8-45R/L	 					T 8
STSCR-10CA-11	 					T 8
STSCR-12CA-16	 					T 15