

# 卡式刀座 30°

## CARTRIDGES ( 30° )

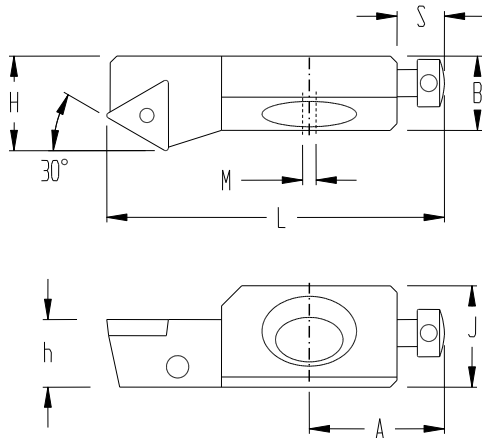

規格 SPECIFICATION	H	h	L	A	J	B	r°	e	M	S	最小加工徑 Min.Bore φD
STB6-30R	7	6	24.5	12	6	5	15°	2.5	1.0	4.5	18
STP8-30R	10	8	34.5	17	8	7	15°	3.2	2.0	7	28
BU133R	12	10	50	19	11.5	10	8°	5.65	2.0	8	35
STTCR-10CA-11	14	10	50	20	15	11	20°	5	2.0	7	38
STTCR-12CA-16	20.5	12	55	20	20	15	20°	6	2.0	8	50

## 部品 PARTS

規格 SPECIFICATION	適用刀片 INSERTS	刀片螺絲 INSERT SCREW	徑向調整螺絲 RADIAL ADJUSTING SCREW	軸向調整螺絲 AXIAL ADJUSTING SCREW	鎖固螺絲 LOCKING SCREW	刀片扳手 INSERT SCREW WRENCH
STB6-30R	TBGT060104	IS200527	RS0305	AS030	LS0312 (M3)	T 6
STP8-30R	TPGT090204	IS250638	RS0306	AS040	LS0412 (M4)	T 8
BU133R	TPGT090204	IS250638	RS0408	AS040	LS0516 (M5)	T 8
STTCR-10CA-11	TCMT110204				LS0616 (M6)	
STTCR-12CA-16	TCMT16T304	IS401155	RS0510	AS050	LS0620 (M6)	T 15