

卡式刀座 30°

CARTRIDGES (30°)

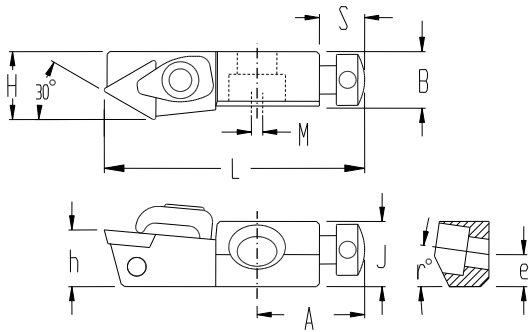

Fig.1

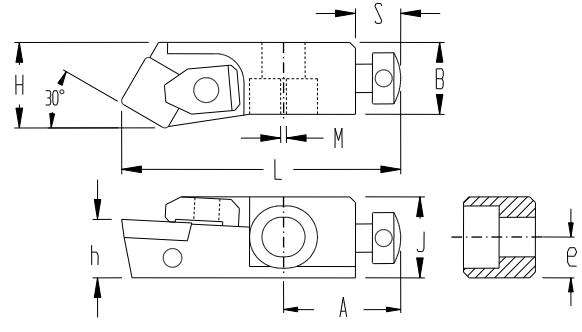

Fig.2

規格 SPECIFICATION	H	h	L	A	J	B	r°	e	M	S	最小加工徑 Min.Bore φD	圖 Fig
CTTER-08CA-11	12	10	46	19	11.5	10	8°	5.65	2.0	8	35	*1
CTTPR-12CA-16	20	12	56.5	20	16	14.5	20°	6	2.0	8	50	*1
CS132PR	15.1	10.31	50	21.4	14.29	12.7	-	7.2	1.5	8.7	45	*2

部品 PARTS

規格 SPECIFICATION	適用刀片 INSERTS		壓版+螺絲 CLAMP +SCREW	徑向調整螺絲 RADIAL ADJUSTING SCREW	軸向調整螺絲 AXIAL ADJUSTING SCREW	鎖固螺絲 LOCKING SCREW
CTTER-08CA-11	TEGN110204	-	172.9-826-1	RS0408	AS040	LS0516 (M5)
CTTPR-12CA-16	TPGN160304	-	CPS-5R	RS0510	AS050	LS0620 (M6)
CS132PR	-	SPGN090308	FC1308-4 +CS0412	RS0410	AS050	LS0620 (M6)