

高速進給銑刀 (接合式&直柄)
HIGH FEED MILLING CUTTER

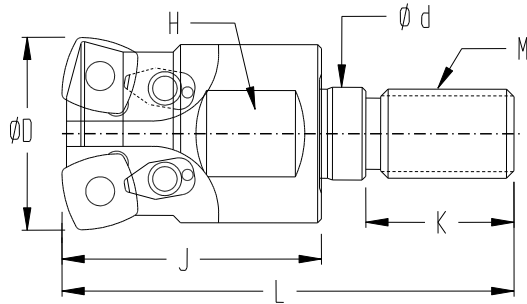

| 規格 SPECIFICATION | φD | J | φd | L | M | K | H | 刀片規格 INSERTS | 刀片螺絲 INSERT SCREW | 壓板 CLAMPS | 壓板螺絲 CLAMPS SCREW | 板手 WRENCH | 刃數 NO.OF INSERT |
|---------------------|----|----|------|----|-----|----|----|--------------------------|-------------------------|----------------|-------------------------|--------------|-----------------------|
| | | | | | | | | | | | | | |
| XEM21XD09M10 | 21 | 35 | 10.5 | 56 | M10 | 15 | 15 | XDLT 090408ER -D41 | IS350850 | FC9505 -2.4 | IS300845 | T 9 T15 | 2 |
| XEM26XD09M12 | 26 | 35 | 12.5 | 61 | M12 | 20 | 21 | | IS351050 | | | | 3 |
| XEM33XD09M16 | 33 | 40 | 17 | 68 | M16 | 22 | 27 | | | | | | |
| XEM40XD09M22 | 40 | 40 | 25 | 75 | M22 | 25 | 35 | | | | | | |

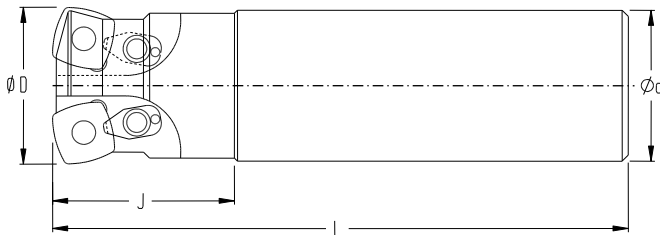

| 規格 SPECIFICATION | φD | J | φd | L | 刀片規格 INSERTS | 刀片螺絲 INSERT SCREW | 壓板 CLAMPS | 壓板螺絲 CLAMPS SCREW | 板手 WRENCH | 刃數 NO.OF INSERT |
|---------------------|----|----|----|-----|--------------------------|-------------------------|----------------|-------------------------|--------------|-----------------------|
| | | | | | | | | | | |
| XEM21XD09ST20 | 21 | 35 | 20 | 110 | XDLT 090408ER -D41 | IS350850 | FC9505 -2.4 | IS300845 | T 9 T15 | 2 |
| XEM26XD09ST25 | 26 | 35 | 25 | 130 | | IS351050 | | | | 3 |
| XEM33XD09ST32 | 33 | 40 | 32 | 150 | | | | | | |
| XEM40XD09ST32 | 40 | 80 | 32 | 150 | | | | | | |

建議切削條件一覽表 Recommended Cutting Conditions

| 工件材質 Workpiece Material | Facing 面銑 | | | Plunging 插銑 | | |
|--------------------------------|-----------------------------|------------------------------|------------------------------|-----------------------------|------------------------------|------------------------------|
| | 速度 Speed Vc (m / min) | 每刃進給 Feed (mm / tooth) | 最大切削深度 max. D.O.C (mm) | 速度 Speed Vc (m / min) | 每刃進給 Feed (mm / tooth) | 最大切削寬度 Max. D.O.C (mm) |
| Unalloyed steels 一般碳鋼 | 120 - 235 | 0.2 - 1.8 | 2.5 | 120 - 235 | 0.10 - 0.25 | 8.0 |
| Alloyed steels 合金鋼 | 70 - 160 | 0.2 - 1.8 | 2.5 | 70 - 160 | 0.10 - 0.18 | 8.0 |
| Stainless steels 不鏽鋼 | 115 - 265 | 0.2 - 1.2 | 2.5 | 115 - 265 | 0.12 - 0.18 | 8.0 |
| Cast Irons 鑄鐵 | 150 - 395 | 0.3 - 1.8 | 2.5 | 150 - 395 | 0.10 - 0.25 | 8.0 |
| Non-ferric metal 鋁、銅、鎂等非鐵金屬 | 400 - 1000 | 0.3 - 1.5 | 2.5 | 400 - 1000 | 0.10 - 0.40 | 8.0 |