

# 卡式刀座 90° CARTRIDGES (90°)

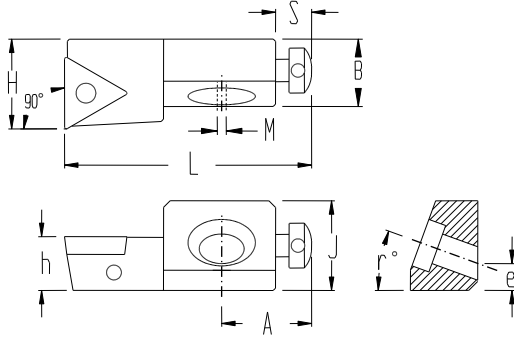

Fig.1

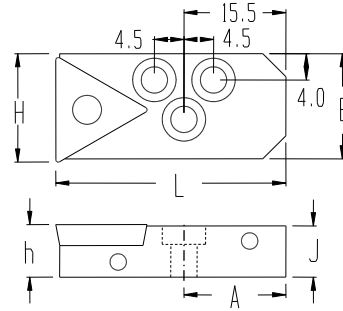

Fig.2

規格 SPECIFICATION	H	h	L	A	J	B	r°	e	M	S	最小加工徑 Min.Bore φD	圖 Fig
STB6-90R/L	7	6	24.5	12	6	5	15°	2.5	1.0	4.5	18	*1
STP8-90R/L	10	8	32	17	8	7	15°	3.2	2.0	7	28	
STFPR-10CA-11	14	10	50	20	15	11	20°	5	2.0	7	38	
STFCR-10CA-11	14	10	50	20	15	11	20°	5	2.0	7	38	
STFCR-12CA-16	20	12	55	20	20	15	20°	6	2.0	8	50	
STFPR-1608-16	16.5	8	35	15.5	7.8	16	-	-	-	-	45	*2

## 部品 PARTS

規格 SPECIFICATION	適用刀片 INSERTS	刀片螺絲 INSERT SCREW	徑向調整螺絲 RADIAL ADJUSTING SCREW	軸向調整螺絲 AXIAL ADJUSTING SCREW	鎖固螺絲 LOCKING SCREW	刀片扳手 INSERT SCREW WRENCH
STB6-90R/L	TBGT060104	IS200527	RS0305	AS030	LS0312 (M3)	T 6
STP8-90R/L	TPGT090204	IS250638	RS0306	AS040	LS0412 (M4)	T8
STFPR-10CA-11	TPGT110304	IS300845	RS0410		LS0620 (M6)	T9
STFCR-10CA-11	TCMT110204	IS250638	RS0410		LS0620 (M6)	T8
STFCR-12CA-16	TCMT16T304	IS401155	RS0510		AS050	LS0620 (M6)
STFPR-1608-16	TPMT160304		RS0312	-	LS0312 (M3)	