

## 卡式刀座 90°

### CARTRIDGES (90°)

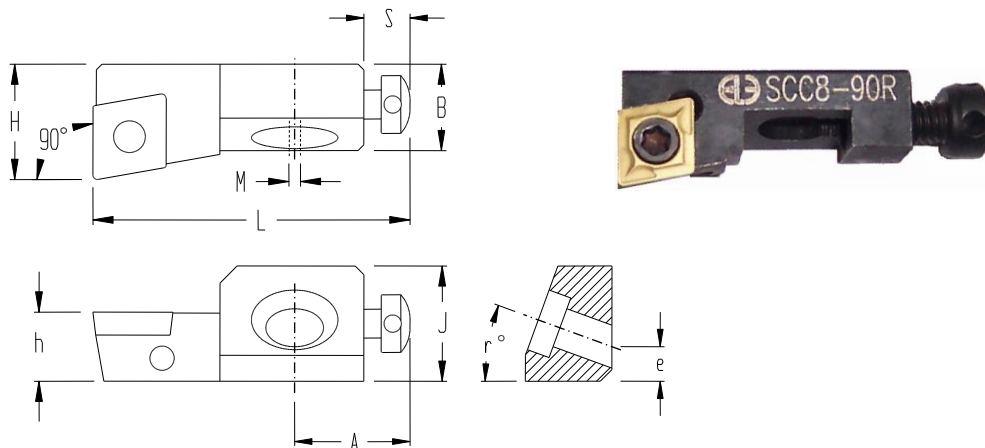

規格 SPECIFICATION	H	h	L	A	J	B	r°	e	M	S	最小加工徑 Min.Bore φD
SEP6 - 90 R	8	6	25	12	6	5	15°	2.5	1.0	4.5	18
SCP6 - 90 R	8	6	25	12	6	5	15°	2.5	1.0	4.5	18
SCC6 - 90 R	10	6	27	12	6	7	15°	2.5	1.0	4.5	24
SCC8 - 90 R	10	8	32	17	8	7	15°	3.2	2.0	7	28
SCFCR-10CA-09	14	10	50	20	15	11	20°	5	2.0	7	38
SCFCR-12CA-12	20	12	55	20	20	15	20°	6	2.0	8	50

## 部品 PARTS

規格 SPECIFICATION	適用刀片 INSERTS	刀片螺絲 INSERT SCREW	徑向調整螺絲 RADIAL ADJUSTING SCREW	軸向調整螺絲 AXIAL ADJUSTING SCREW	鎖固螺絲 LOCKING SCREW	刀片扳手 INSERT SCREW WRENCH
SEP6 - 90R	EPEX040202	IS200527	RS0305	AS030	LS0312 (M3)	T 6
SCP6 - 90R	CPGT050204	IS2205335				T 7
SCC6 - 90R	CCMT060204	IS250638	RS0306	AS030	LS0312 (M3)	T 8
SCC8 - 90R						
SCFCR-10CA-09	CCMT09T304	IS401155	RS0410	AS040	LS0616 (M6)	T 15
SCFCR-12CA-12	CCMT120408	IS501170	RS0510	AS050	LS0620 (M6)	T 20