

微調精磨單元 (XMBU)

MICRO-ADJUSTABLE FINE BORING UNIT

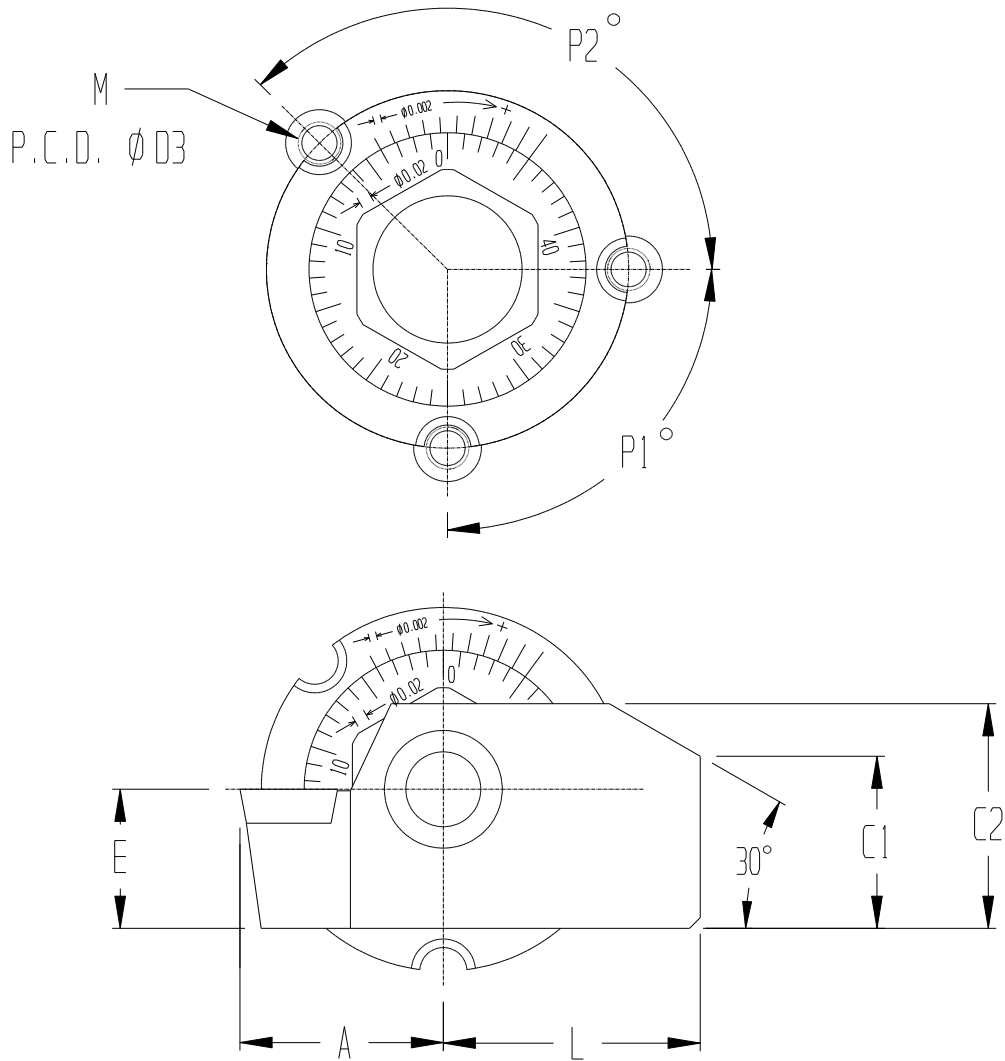

規格 SPECIFICATION	M	$P1^\circ$	$P2^\circ$	$\phi D3$	E	A	L	C1	C2	固定螺絲 LOCKING SCREW	刀片螺絲 INSERT SCREW	調整板手 ADJUSTING WRENCH
XMBU25	M2.2*P0.45	120°	120°	20	6.6	12.5	13.5	8.66	12	IS220534	IS200527	AWH25
XMBU28	M2.2*P0.45	120°	120°	20	6.6	12.5	13.5	8.66	12	IS220534	IS200527	AWH25
XMBU40	M3*P0.5	90°	135°	27.5	7.6	15	17.5	9.66	14	IS300845	IS250638	AWH40
XMBU50	M4*P0.7	90°	135°	34	13	19	24	16.09	21	IS401155	IS300845	AWH50
XMBU60	M4*P0.7	90°	135°	34	13	19	24	16.09	21	IS401155	IS401155	AWH50